

LOW LEAKAGE CURRENT

低漏電品

- Low leakage current (0.5 ~ 3.3µA max.)
低漏電流 (0.5 ~ 3.3µA 最大值)
- Low cost for replacement of some tantalum applications
可替換價格較高的鉭電容器
- Comply with the RoHS directive
符合 RoHS 指令



SPECIFICATIONS 特性表

Items 項目	Characteristics 主要特性																					
Operation Temperature Range 使用溫度範圍	-40 ~ +85°C																					
Voltage Range 額定工作電壓範圍	6.3 ~ 50V																					
Capacitance Range 靜電容量範圍	0.1 ~ 220µF																					
Capacitance Tolerance 靜電容量允許偏差	±20% at 120Hz, 20°C																					
Leakage Current 漏電流	Leakage current $\leq 0.002CV$ or 0.5µA, whichever is greater (after 2 minutes application of rated voltage) 漏電流 $\leq 0.002CV$ 或 0.5µA, 取較大值 (施加額定工作電壓 2 分鐘後)																					
Surge Voltage & Dissipation Factor (tan δ) 浪湧電壓和損耗角正切	Measurement frequency 測試頻率: 120Hz, Temperature 溫度: 20°C																					
	<table border="1"> <tr> <td>Rated Voltage (V) 額定工作電壓</td> <td>6.3</td> <td>10</td> <td>16</td> <td>25</td> <td>35</td> <td>50</td> </tr> <tr> <td>Surge voltage 浪湧電壓</td> <td>8.0</td> <td>13</td> <td>20</td> <td>32</td> <td>44</td> <td>63</td> </tr> <tr> <td>tan δ (max.) 最大損耗角正切</td> <td>0.24</td> <td>0.20</td> <td>0.16</td> <td>0.14</td> <td>0.12</td> <td>0.10</td> </tr> </table>	Rated Voltage (V) 額定工作電壓	6.3	10	16	25	35	50	Surge voltage 浪湧電壓	8.0	13	20	32	44	63	tan δ (max.) 最大損耗角正切	0.24	0.20	0.16	0.14	0.12	0.10
	Rated Voltage (V) 額定工作電壓	6.3	10	16	25	35	50															
Surge voltage 浪湧電壓	8.0	13	20	32	44	63																
tan δ (max.) 最大損耗角正切	0.24	0.20	0.16	0.14	0.12	0.10																
Stability at Low Temperature 低溫特性	Measurement frequency 測試頻率: 120Hz																					
	<table border="1"> <tr> <td>Rated Voltage (V) 額定工作電壓</td> <td>6.3</td> <td>10</td> <td>16, 25</td> <td>35, 50</td> </tr> <tr> <td rowspan="2">Impedance Ratio 阻抗比</td> <td>Z(-25°C) / Z(20°C)</td> <td>4</td> <td>3</td> <td>2</td> <td>2</td> </tr> <tr> <td>ZT/Z20 (max.)</td> <td>8</td> <td>6</td> <td>4</td> <td>3</td> </tr> </table>	Rated Voltage (V) 額定工作電壓	6.3	10	16, 25	35, 50	Impedance Ratio 阻抗比	Z(-25°C) / Z(20°C)	4	3	2	2	ZT/Z20 (max.)	8	6	4	3					
Rated Voltage (V) 額定工作電壓	6.3	10	16, 25	35, 50																		
Impedance Ratio 阻抗比	Z(-25°C) / Z(20°C)	4	3	2	2																	
	ZT/Z20 (max.)	8	6	4	3																	
Load Life 高溫負荷特性	After 2000 hours application of the rated voltage at 85°C, they meet the characteristics listed below. 在 85°C 環境中施加額定工作電壓 2000 小時後, 電容器的特性符合下表的要求。																					
	<table border="1"> <tr> <td>Capacitance Change 靜電容量變化率</td> <td>Within ±25% of initial value 初始值的±25%以內</td> </tr> <tr> <td>Dissipation Factor 損耗角正切</td> <td>200% or less of initial specified value 不大於規範值的 200%</td> </tr> <tr> <td>Leakage Current 漏電流</td> <td>initial specified value or less 不大於規範值</td> </tr> </table>	Capacitance Change 靜電容量變化率	Within ±25% of initial value 初始值的±25%以內	Dissipation Factor 損耗角正切	200% or less of initial specified value 不大於規範值的 200%	Leakage Current 漏電流	initial specified value or less 不大於規範值															
	Capacitance Change 靜電容量變化率	Within ±25% of initial value 初始值的±25%以內																				
Dissipation Factor 損耗角正切	200% or less of initial specified value 不大於規範值的 200%																					
Leakage Current 漏電流	initial specified value or less 不大於規範值																					
Resistance to Soldering Heat 耐焊接熱特性	After reflow soldering and restored at room temperature, they meet the characteristics listed below. 經過回流焊並冷卻至室溫後, 電容器的特性符合下表的要求。																					
	<table border="1"> <tr> <td>Capacitance Change 靜電容量變化率</td> <td>Within ±10% of initial value 初始值的±10%以內</td> </tr> <tr> <td>Dissipation Factor 損耗角正切</td> <td>initial specified value or less 不大於規範值</td> </tr> <tr> <td>Leakage Current 漏電流</td> <td>initial specified value or less 不大於規範值</td> </tr> </table>	Capacitance Change 靜電容量變化率	Within ±10% of initial value 初始值的±10%以內	Dissipation Factor 損耗角正切	initial specified value or less 不大於規範值	Leakage Current 漏電流	initial specified value or less 不大於規範值															
	Capacitance Change 靜電容量變化率	Within ±10% of initial value 初始值的±10%以內																				
Dissipation Factor 損耗角正切	initial specified value or less 不大於規範值																					
Leakage Current 漏電流	initial specified value or less 不大於規範值																					
Marking 標示	Black print on the case top. 鋁殼頂部黑字印刷。																					

DRAWING (Unit: mm) 外形圖

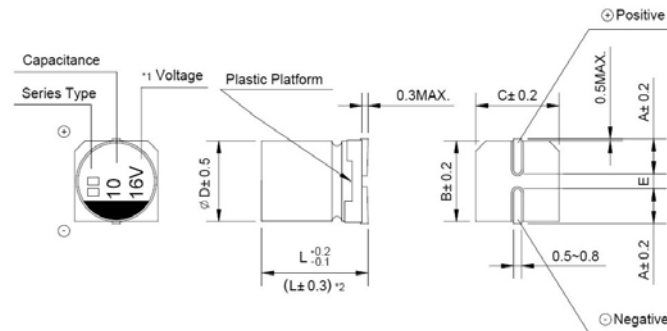

- *1. Voltage mark for 6.3V is [6V] 6.3V 的產品標識為 [6V]
 *2. Applicable to $\varnothing 6.3 \times 7.7$ 適用於 $\varnothing 6.3 \times 7.7$

DIMENSIONS (Unit: mm) 尺寸表

ØD x L	4 x 5.4	5 x 5.4	6.3 x 5.4	6.3 x 7.7
A	1.8	2.1	2.4	2.4
B	4.3	5.3	6.6	6.6
C	4.3	5.3	6.6	6.6
E ± 0.2	1.0	1.3	2.2	2.2
L	5.4	5.4	5.4	7.7

NOTE: All designs and specifications are for reference only and are subject to change without prior notice. If any doubt about safety for your application, please contact us immediately for technical assistance before purchase.

注: 以上所提供的設計及特性參數僅供參考, 任何修改不預先通知。如果在使用上有疑問, 請在採購前與我們聯繫, 以便提供技術上的協助。

□ DIMENSIONS & MAXIMUM PERMISSIBLE RIPPLE CURRENT & ESR 規格尺寸及最大允許紋波電流及 ESR 值

WV		6.3 (0J)			10 (1A)			16 (1C)		
Parameter 參數 μF	Case size ∅D×L (mm) 尺寸	E.S.R. (Ω) 20°C 120Hz E.S.R.值	Ripple current (mA rms) at 85°C 120Hz 紋波電流	Case size ∅D×L (mm) 尺寸	E.S.R. (Ω) 20°C 120Hz E.S.R.值	Ripple current (mA rms) at 85°C 120Hz 紋波電流	Case size ∅D×L (mm) 尺寸	E.S.R. (Ω) 20°C 120Hz E.S.R.值	Ripple current (mA rms) at 85°C 120Hz 紋波電流	
										10
10	100						4 × 5.4	34.5	25	
22	220	4 × 5.4	23.5	31	5 × 5.4	19.6	35	5 × 5.4	39	
33	330	5 × 5.4	15.7	39	5 × 5.4	13.1	43	6.3 × 5.4	57	
47	470	5 × 5.4	11.0	47	6.3 × 5.4	9.2	59	6.3 × 5.4	68	
100	101	6.3 × 5.4	5.2	75	6.3 × 5.4	4.3	76	6.3 × 7.7	96	
220	221	6.3 × 7.7	2.4	85						

WV		25 (1E)			35 (1V)			50 (1H)		
Parameter 參數 μF	Case size ∅D×L (mm) 尺寸	E.S.R. (Ω) 20°C 120Hz E.S.R.值	Ripple current (mA rms) at 85°C 120Hz 紋波電流	Case size ∅D×L (mm) 尺寸	E.S.R. (Ω) 20°C 120Hz E.S.R.值	Ripple current (mA rms) at 85°C 120Hz 紋波電流	Case size ∅D×L (mm) 尺寸	E.S.R. (Ω) 20°C 120Hz E.S.R.值	Ripple current (mA rms) at 85°C 120Hz 紋波電流	
										0.1
0.1	0R1						4 × 5.4	2156	1.0	
0.22	R22						4 × 5.4	980	2.3	
0.33	R33						4 × 5.4	653	3.5	
0.47	R47						4 × 5.4	459	5	
1	010						4 × 5.4	216	10	
2.2	2R2						4 × 5.4	98	15	
3.3	3R3						4 × 5.4	65	18	
4.7	4R7	4 × 5.4	64.2	19	4 × 5.4	55.1	20	5 × 5.4	23	
10	100	5 × 5.4	30.2	28	5 × 5.4	25.9	30	6.3 × 5.4	34	
22	220	6.3 × 5.4	13.7	52	6.3 × 5.4	11.8	54	6.3 × 7.7	85	
33	330	6.3 × 5.4	9.1	63	6.3 × 7.7	7.8	105			
47	470	6.3 × 7.7	6.4	100	6.3 × 7.7	5.5	110			

□ FREQUENCY COEFFICIENT OF ALLOWABLE RIPPLE CURRENT 紋波電流頻率補償系數

Frequency 頻率	~50Hz	120Hz	300Hz	1KHz	10KHz~
Coefficient 系數	0.70	1.00	1.17	1.36	1.50

- Taping specifications are given in page 11. 編帶標準請參閱第 11 頁。
- Please refer to page 12 for the minimum package quantity. 最小包裝數量請參閱第 12 頁。

NOTE: All designs and specifications are for reference only and are subject to change without prior notice. If any doubt about safety for your application, please contact us immediately for technical assistance before purchase.

注：以上所提供的設計及特性參數僅供參考，任何修改不作預先通知。如果在使用上有疑問，請在採購前與我們聯繫，以便提供技術上的協助。