

# Reel Specifications for Surface Mounted Glass Diodes

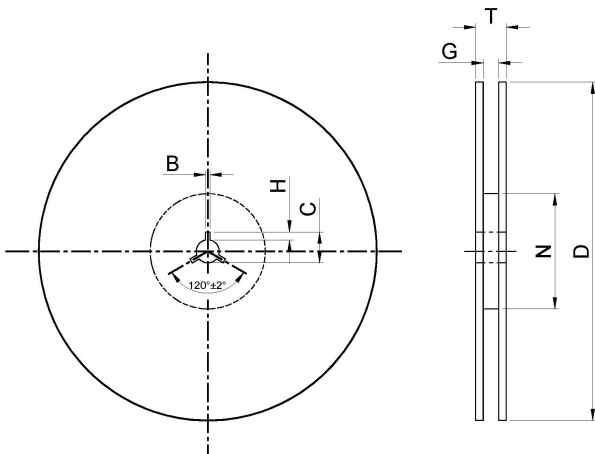

The beginning of the tape comprises a 200 mm long lead-in with vacant nests and at the hub end of the tape there are 10 to 20 sealed nests containing no devices. This end of the tap automatically detaches from the hub of the reel at the end of the inreeling procedure.

The packaging units for taped devices are

Type of case	Qty / reel	Reel Ø
MELF	5,000	330 mm
MiniMELF	2,500	178 mm
QuadroMELF	2,500	178 mm
MicroMELF	2,500	178 mm

Symbol	8-mm carrier tape	12-mm carrier tape
B	2 ±0.5	2 ±0.5
C	13 ±0.5	13 ±0.5
D	178 ±2	330 ±2
G	8.4 ±1.5	12.4 ±2
H	4 ±0.5	4 ±0.5
N	60	60
T	< 14.9	< 20

Dimensions in mm

Pull-out direction

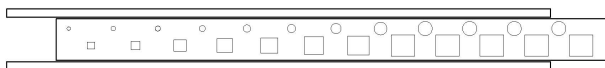

Reel for 8-mm and 12-mm carrier tapes

The carrier tape consists of a plastic tape with "nests" having a size corresponding to the components requirements. The sprocket holes are on one side of the tape. The blister tapes are sealed with a cover tape.

The cathode side of the components in MELF, MiniMELF, QuadroMELF and MicroMELF cases are adjacent to the sprocket holes. Other orientation can be supplied on demand.