

# Packaging Specifications of Bulk Pack for Lead Type Diodes

1. The method of packaging and dimension are shown as below figure. (Dimension in mm)

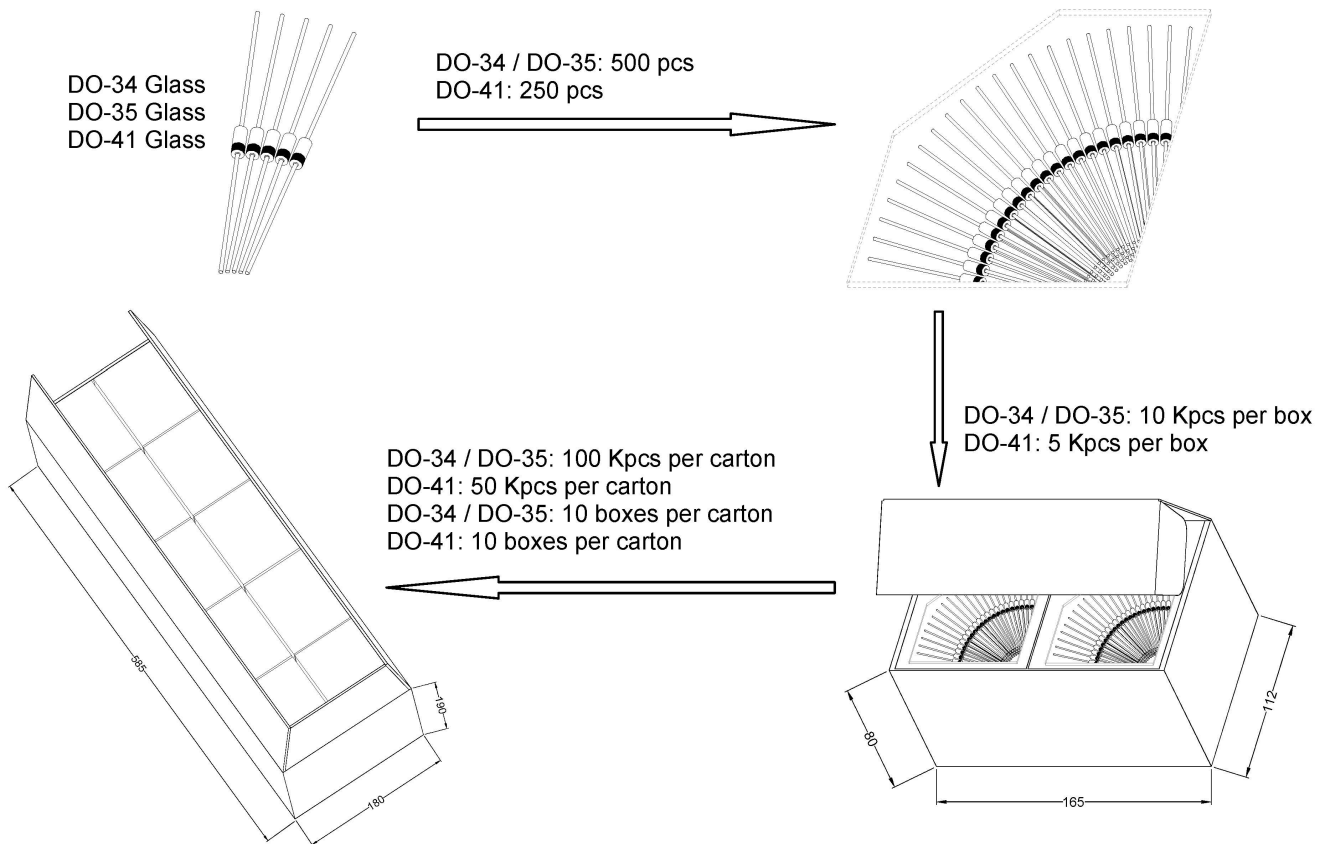

## 2. Label

2.1 The information of inner box label must be listed: (Description of a sample lable)

- 2.1.1 **TYPEBZX55C2V0ST** means (Product) TYPE (Part No.)
- 2.1.2 **QTY 10,000 PCS** means (Product) Quantity (QTY)
- 2.1.3 **D/C TT0C2H0129Z020** means Dice Lot No. / Code (D/C)
- 2.1.4 **P/C 80092032** means Production Code (P/C)
- 2.1.5 **RMK80303 G PX H =** means Manufacturing Date (RMK)

2.2 The information of carton label must be listed:

2.2.1 TYPE

2.2.2 QTY